



Conventional fire alarm sounder

**SPP-110**

Firmware version 1.00

**EN**

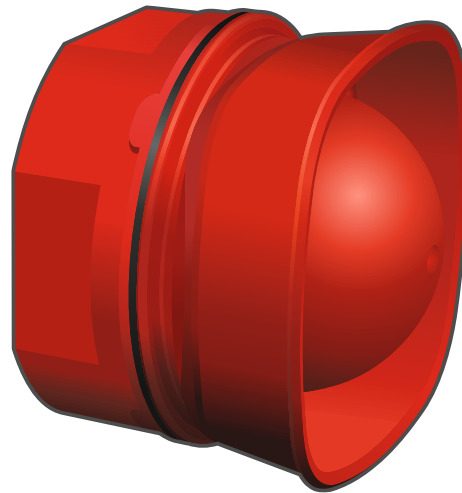

spp-110\_en 04/24

**Satel**®

SATEL sp. z o.o. • ul. Budowlanych 66 • 80-298 Gdańsk • POLAND  
tel. +48 58 320 94 00  
[www.satel.pl](http://www.satel.pl)

## IMPORTANT

The device should be installed by qualified personnel.

Prior to installation, please read carefully this manual in order to avoid mistakes that can lead to malfunction or even damage to the equipment.

Disconnect power before making any electrical connections.

Changes, modifications or repairs not authorized by the manufacturer shall void your rights under the warranty.

The following symbols may be used in this manual:



- note,



- caution.

The SPP-110 sounder is used for acoustic alarm signaling. The sounder is designed to work with the SATEL fire alarm control panels (conventional: CSP-104, CSP-108, CSP-204, CSP-208; addressable: ACSP-402).

## 1. Features

- Acoustic signaling by means of piezoelectric transducer.
- 32 selectable tones.
- Selectable volume level.

## 2. Installation



**Disconnect power before making any electrical connections.**

The sounder is designed for installation indoors, in spaces with normal air humidity.

1. Turn the cover counter-clockwise and remove it (Fig. 1).
2. Drill the holes for screws in the enclosure base. Use the countersunk screws (Fig. 2) or the non-countersunk screws (Fig. 3) to fasten the enclosure base to the wall.
3. Drill the hole for cables in the enclosure base (Fig. 4).

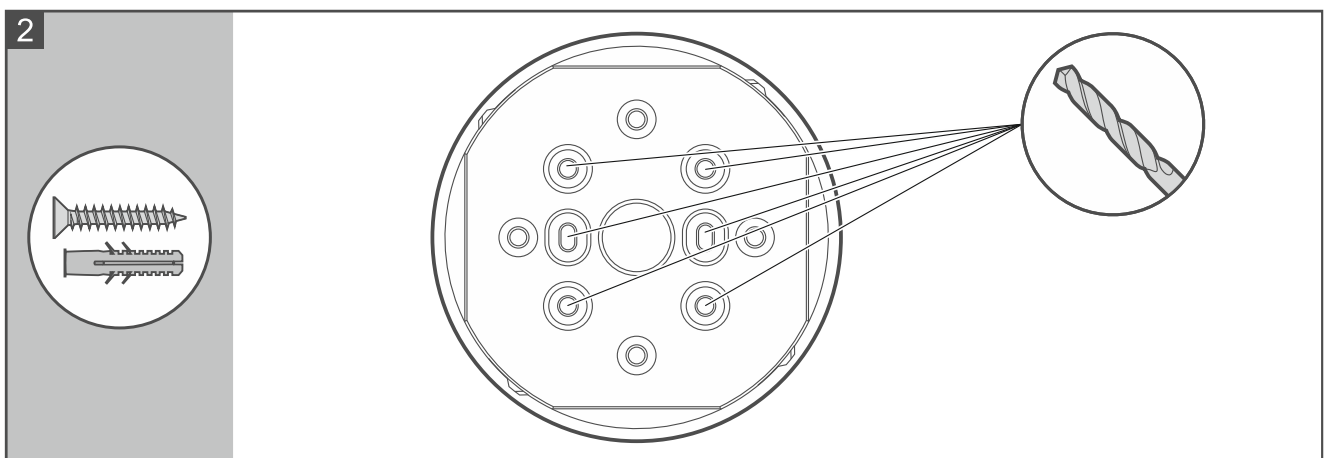
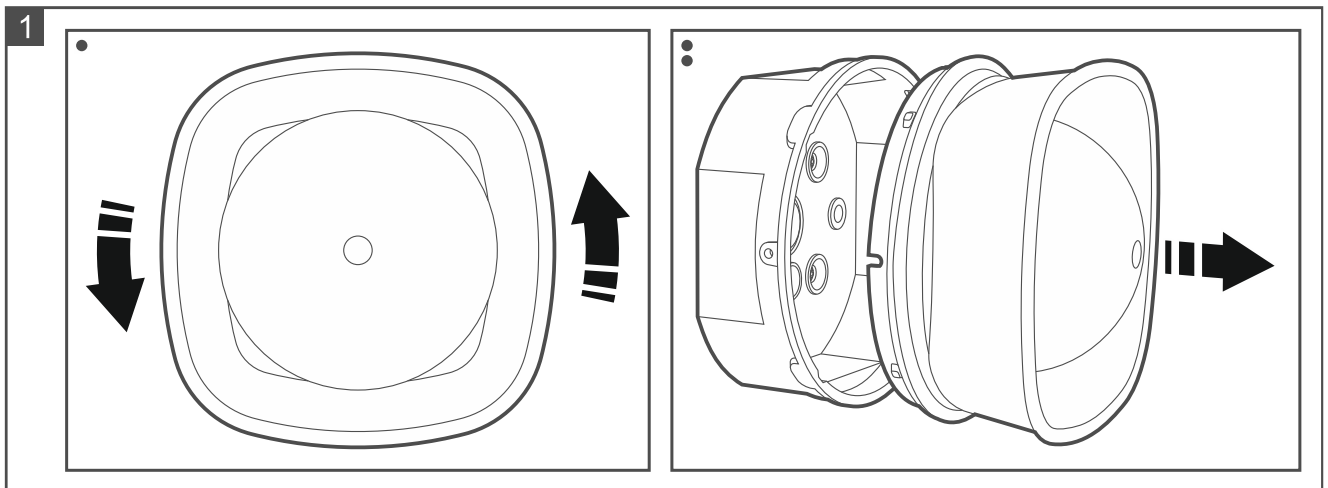

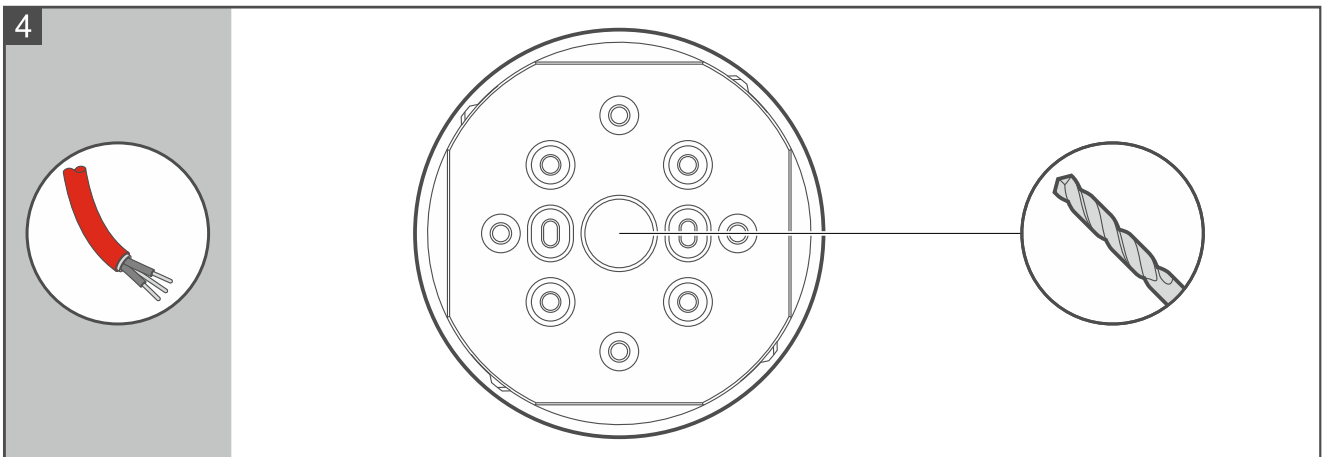
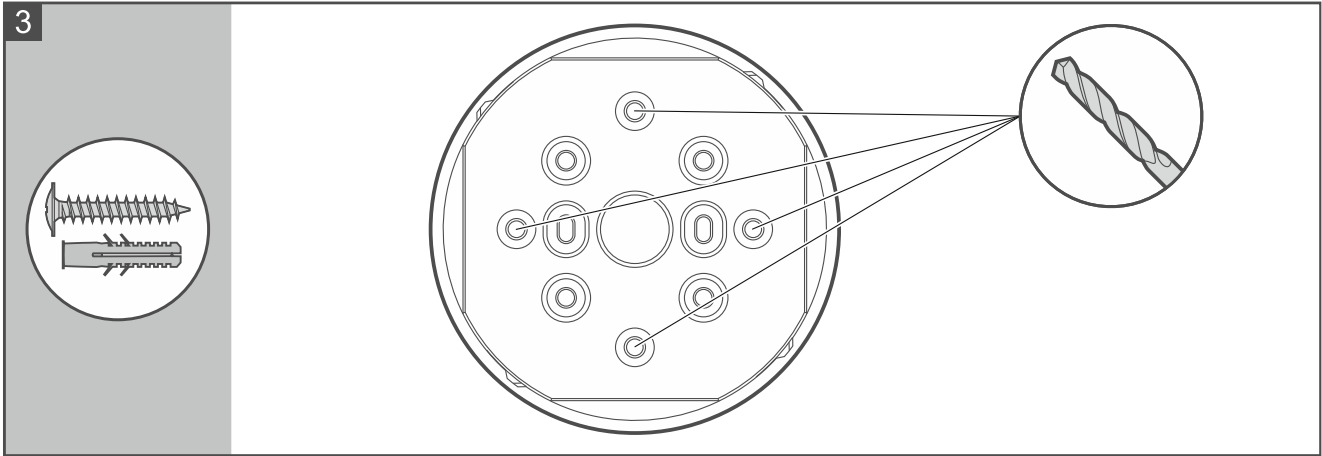

4. Place the enclosure base against the wall and mark the location of mounting holes.
5. Drill the holes for wall plugs (screw anchors) in the wall.
6. Run the cables inside the enclosure base.
7. Use wall plugs and screws to secure the enclosure base to the wall. Select wall plugs specifically intended for the mounting surface (different for concrete or brick wall, different for plaster wall, etc.).
8. Use the DIP switches to configure the sounder settings (see: “Configuring the sounder settings” p. 3).
9. Connect the zone circuit wires to the sounder (Fig. 5). If the sounder is connected to the zone circuit at the end of line, screw a 10 k $\Omega$  resistor to its terminals. You can connect the cable shields to the E terminals (using a shielded cable is not required).

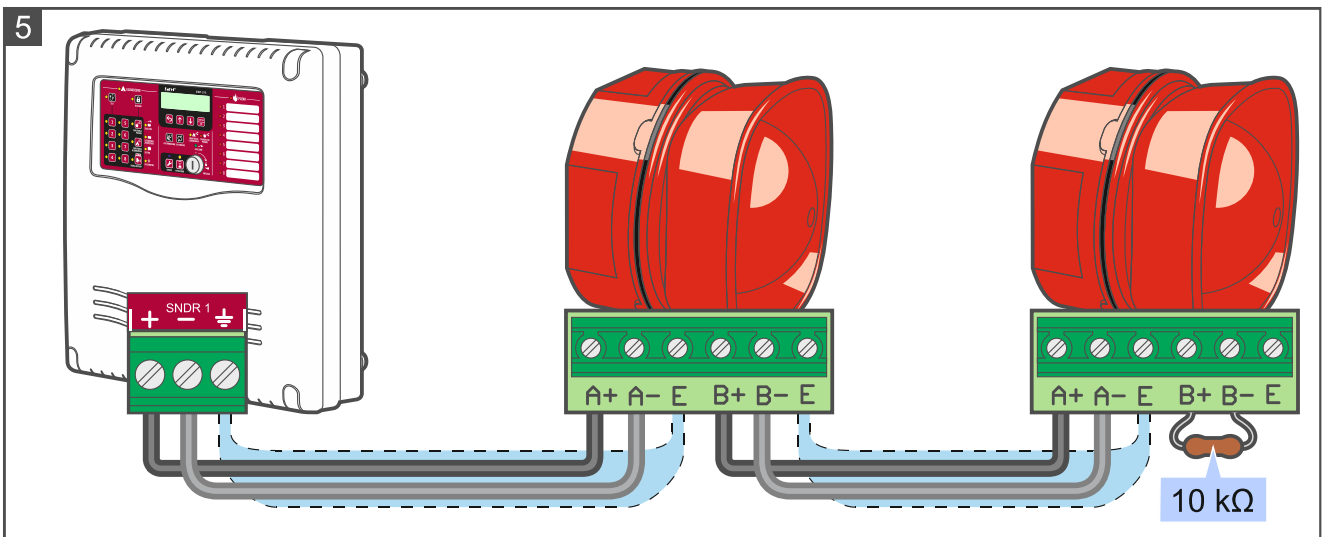

10. Replace the cover and turn it clockwise (Fig. 6).

11. Lock the cover with a screw (Fig. 7).

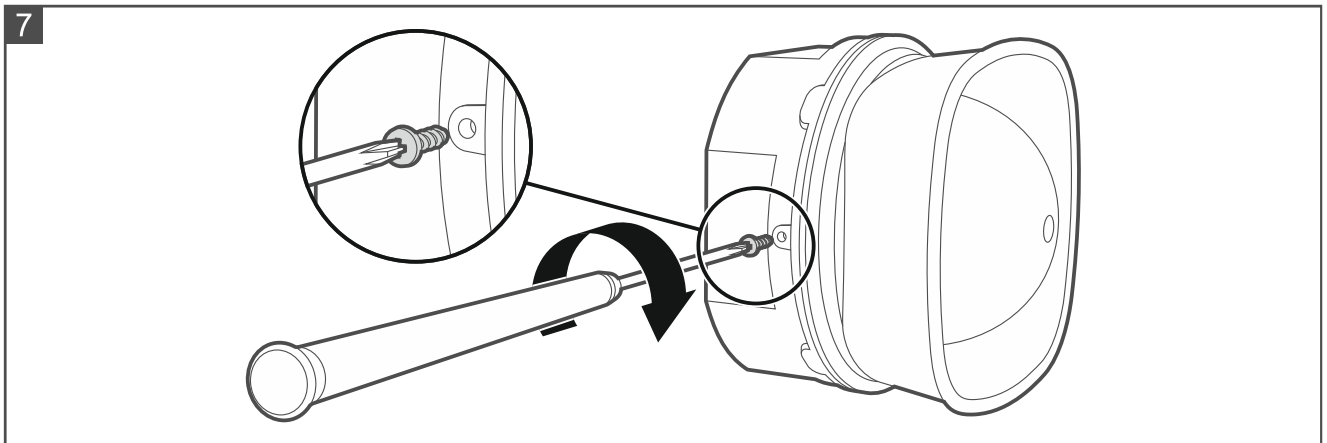
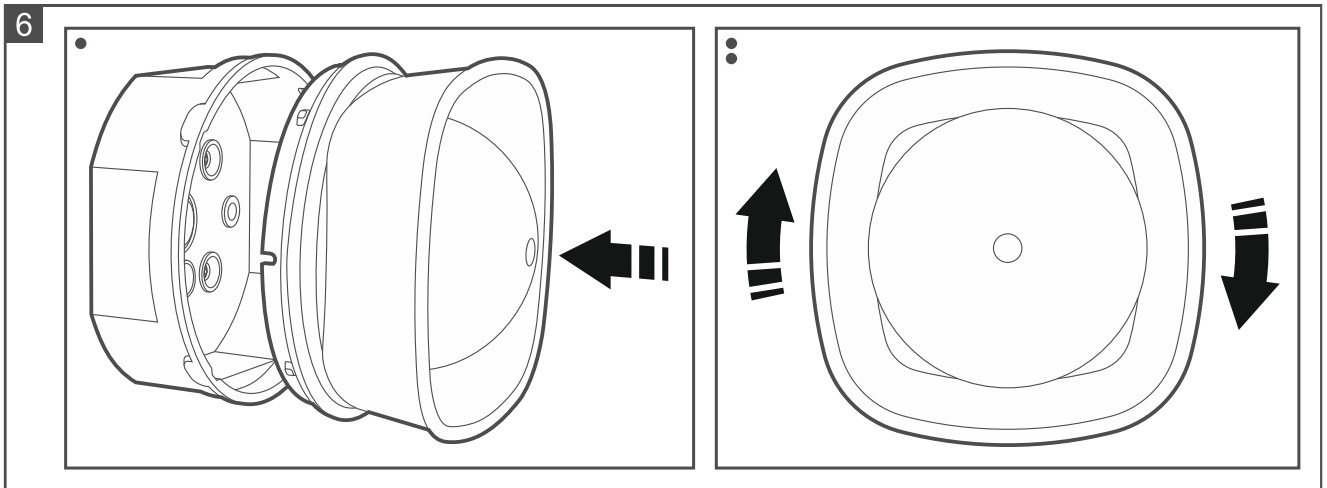

## 2.1 Configuring the sounder settings

Use the DIP switches on the electronics board (Fig. 8) to configure the sounder settings.

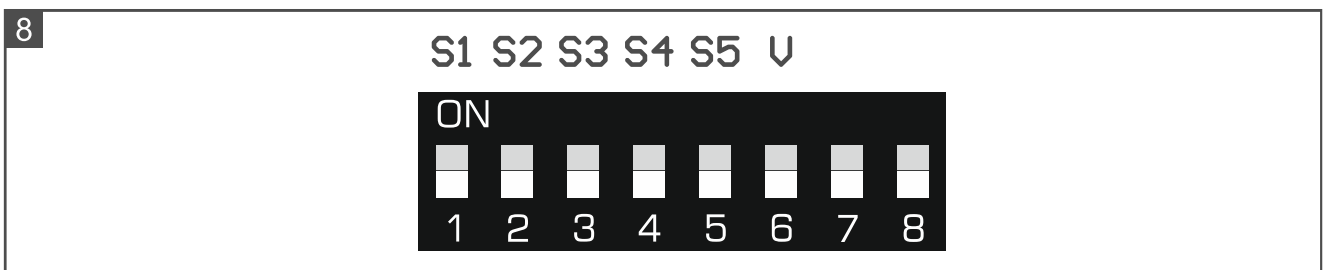

### 2.1.1 Selecting the tone

To select the tone, use the switches 1-5, marked as S1-S5 on the electronics board. The tones and their corresponding switch settings are described in Table 1 (where: switch in ON position = 1; switch in OFF position = 0).

N	DIP switch	Acoustic signaling		
	12345		Frequency Hz	Description
1	00000		800 & 970	2 Hz (250 ms – 250 ms)
2	10000		800-970	7 Hz (7/s)
3	01000		800-970	1 Hz (1/s)
4	11000		2850	Continuous



























No	DIP switch	Acoustic signaling		
	12345		Frequency Hz	Description
5	00100		2400-2850	7 Hz
6	10100		2400-2850	1 Hz
7	01100		500-1200	3 s sound, 0.5 s silence, repeated
8	11100		1200-500	1 Hz
9	00010		2400-2850	2 Hz (250 ms – 250 ms)
10	10010		970	0.5 Hz (1 s)
11	01010		800 & 970	1 Hz (500 ms – 500 ms)
12	11010		2850	0.5 Hz (1 s)
13	00110		970	0.8 Hz (250 ms / 1 s)
14	10110		970	Continuous
15	01110		554 & 440	100 ms – 400 ms
16	11110		660	3.3 Hz (150 ms)
17	00001		660	0.28 Hz (1.8 s)
18	10001		660	0.05 Hz (13 s / 6.5 Hz)
19	01001		660	Continuous
20	11001		554 & 440	0.5 Hz (1 s)
21	00101		660	1 Hz (500 ms – 500 ms)
22	10101		2850	4 Hz (150 ms – 100 ms)
23	01101		800-970	50 Hz
24	11101		2400-2850	50 Hz
25	00011		970	3 x 500 ms sound, 1.5 s silence, repeated
26	10011		800-970	3 x 500 ms sound, 1.5 s silence, repeated
27	01011		970 & 800	3 x 500 ms sound, 1.5 s silence, repeated
28	11011		2400	Continuous
29	00111		990 & 650	2 Hz (250 ms – 250 ms) (Symphoni Tones)
30	10111		510 & 610	2 Hz (250 ms – 250 ms) (Squashni Micro Tones)
31	01111		300-1200	1 Hz
32	11111		510 & 610	1 Hz (500 ms – 500 ms)

Table 1.

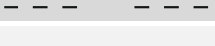
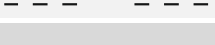
Tone / supply voltage	Angle-dependent [°] minimum sound level [dBA]					
	15°	45°	75°	105°	135°	165°
1 / 18 VDC	74.3	85.7	89.9	89.4	84.2	77.0
1 / 28 VDC	77.0	87.2	91.4	90.9	85.8	80.0
2 / 18 VDC	78.0	85.7	89.1	88.8	83.5	78.0
2 / 28 VDC	79.6	87.5	90.7	90.4	85.4	79.9
3 / 18 VDC	78.9	86.1	90.0	89.7	83.9	78.2
3 / 28 VDC	80.9	87.8	91.3	91.0	85.8	80.3
4 / 18 VDC	71.0	81.0	83.5	82.0	79.7	69.6
4 / 28 VDC	71.3	81.4	84.04	82.6	79.7	69.7
5 / 18 VDC	75.3	83.4	85.6	85.0	81.1	75.0
5 / 28 VDC	75.2	83.4	85.5	85.0	81.0	74.5
6 / 18 VDC	76.6	84.7	86.7	86.4	82.6	75.1
6 / 28 VDC	76.4	84.6	86.4	86.1	82.6	75.1
7 / 18 VDC	79.8	87.2	91.8	91.5	85.8	81.5

Tone / supply voltage	Angle-dependent [°] minimum sound level [dBA]					
	15°	45°	75°	105°	135°	165°
7 / 28 VDC	80.9	88.6	92.8	92.6	87.3	82.9
8 / 18 VDC	78.6	86.5	90.5	90.3	84.6	80.7
8 / 28 VDC	80.2	88.3	92.1	91.8	86.5	82.6
9 / 18 VDC	77.0	81.0	86.9	86.1	80.2	75.8
9 / 28 VDC	77.0	81.3	87.0	86.2	80.1	75.7
10 / 18 VDC	73.2	86.3	90.6	90.3	84.9	76.6
10 / 28 VDC	74.2	87.2	91.6	91.3	85.9	77.6
11 / 18 VDC	74.6	86.5	90.7	90.3	85.0	77.2
11 / 28 VDC	77.3	87.8	91.9	91.5	86.5	80.2
12 / 18 VDC	73.4	84.1	86.9	88.4	85.9	73.8
12 / 28 VDC	77.5	87.8	90.5	91.9	89.4	76.6
13 / 18 VDC	72.7	85.7	90.0	89.7	84.1	75.9
13 / 28 VDC	73.9	86.7	91.1	90.9	85.3	77.2
14 / 18 VDC	73.1	86.2	90.5	90.2	84.8	76.5
14 / 28 VDC	73.4	86.2	90.8	90.3	84.8	76.5
15 / 18 VDC	75.9	83.6	86.9	86.4	80.1	77.6
15 / 28 VDC	77.5	84.8	88.4	87.9	81.0	79.3
16 / 18 VDC	75.9	84.9	87.4	87.0	81.7	74.8
16 / 28 VDC	77.4	86.3	89.0	88.6	83.0	76.3
17 / 18 VDC	76.8	86.0	88.5	88.2	83.0	75.8
17 / 28 VDC	78.6	87.4	90.2	89.7	84.3	77.4
18 / 18 VDC	77.2	86.1	88.6	88.2	82.9	76.0
18 / 28 VDC	78.7	87.4	90.3	89.9	84.3	77.5
19 / 18 VDC	77.0	85.9	88.4	88.2	83.0	75.8
19 / 28 VDC	78.7	87.4	90.2	89.8	84.3	77.4
20 / 18 VDC	76.0	84.1	87.4	87.0	80.2	77.9
20 / 28 VDC	77.5	85.4	88.6	88.3	81.5	79.5
21 / 18 VDC	76.9	85.9	88.4	88.1	82.7	75.7
21 / 28 VDC	78.5	87.3	90.0	89.5	84.1	77.2
22 / 18 VDC	74.0	84.0	86.0	85.6	82.8	73.0
22 / 28 VDC	74.8	84.6	86.5	85.6	83.4	73.5
23 / 18 VDC	77.4	85.4	88.5	88.0	83.1	77.5
23 / 28 VDC	79.4	87.3	90.4	90.0	85.0	79.5
24 / 18 VDC	75.6	83.3	85.4	84.9	80.6	74.4
24 / 28 VDC	75.4	83.4	85.6	84.7	80.3	74.4
25 / 18 VDC	73.3	86.5	90.8	90.5	85.1	76.6
25 / 28 VDC	74.6	87.6	91.9	91.5	86.1	77.6
26 / 18 VDC	78.0	85.8	89.7	89.3	83.4	77.6
26 / 28 VDC	80.0	87.1	91.2	90.7	84.8	79.2
27 / 18 VDC	74.7	86.0	90.3	90.0	84.4	77.3
27 / 28 VDC	77.4	87.5	91.5	91.3	86.1	80.0
28 / 18 VDC	75.4	79.6	85.6	87.0	80.9	76.3
28 / 28 VDC	75.5	79.7	85.8	87.1	80.9	76.3
29 / 18 VDC	78.9	88.2	91.1	90.7	85.2	77.6
29 / 28 VDC	79.9	89.2	91.9	91.7	86.0	78.4

Tone / supply voltage	Angle-dependent [°] minimum sound level [dBA]					
	15°	45°	75°	105°	135°	165°
30 / 18 VDC	76.4	84.9	87.6	87.3	81.8	76.1
30 / 28 VDC	77.9	86.3	89.0	88.8	83.1	77.7
31 / 18 VDC	77.8	86.0	89.8	89.5	83.9	79.4
31 / 28 VDC	78.4	86.6	90.4	90.1	84.6	80.1
32 / 18 VDC	76.4	85.1	87.6	87.4	81.9	76.2
32 / 28 VDC	77.9	86.5	89.2	89.0	83.0	77.8

Table 2.

### 2.1.2 Volume setting

Use the switch 6 (marked as V on the electronics board) to change the volume of the following tones: 4, 5, 6, 9, 12, 14, 22 and 28. The switch in ON position – maximum volume (recommended). The switch in OFF position – lower volume. For other tones, it is recommended to set the switch to OFF position.

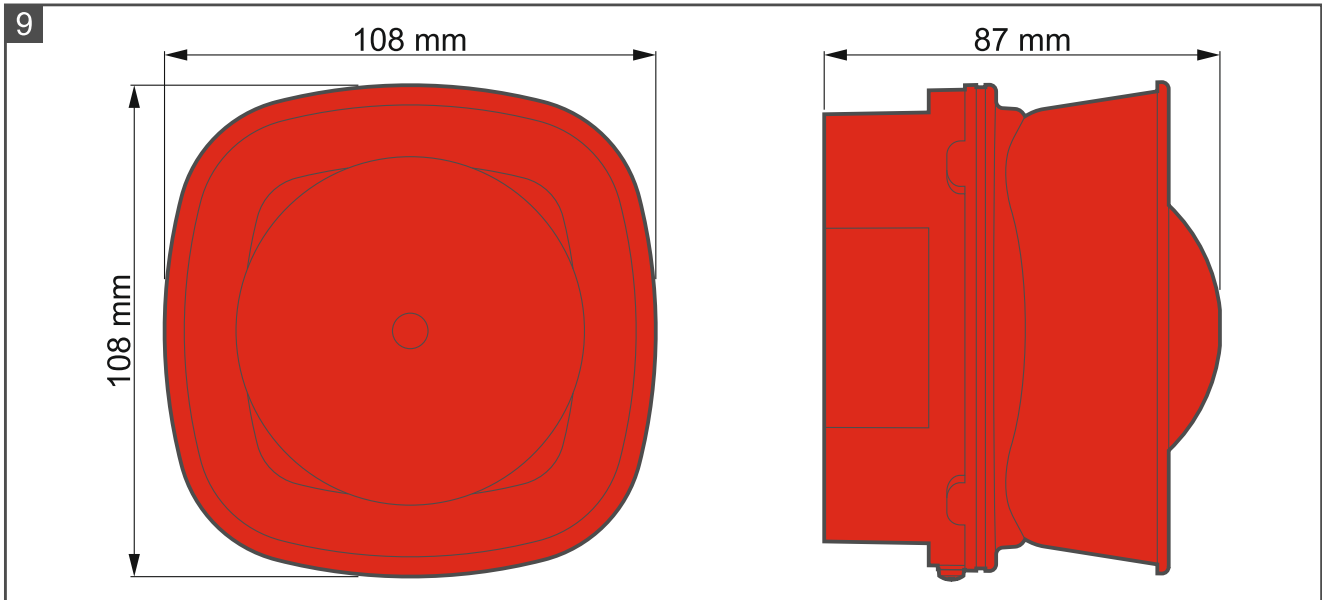

## 3. Maintenance

The fire alarm system elements require regular maintenance. The periodic checks of the SPP-110 sounder should be carried out at least every 6 months. In spaces where working conditions are difficult (e.g. dust, aggressive environment that may cause corrosion, etc.), the periodic checks should be carried out more often.

As part of maintenance, start a test in the control panel and make sure the acoustic signaling is working. Please go to the fire alarm control panel manuals to find out how to start the test.

## 4. Specifications

Supply voltage .....	18..28 VDC
Alarm current consumption .....	15 mA
Operating temperature range .....	-10°C...+55°C
Maximum humidity .....	95%
Protection rating .....	IP21C
Operating environment type .....	A



---

Dimensions .....	108 x 108 x 87 mm
Weight.....	225 g

The SPP-110 fire alarm sounder conforms to the essential requirements of the EU Regulations and Directives:

**CPR 305/2011** Regulation of the European Parliament and of the Council of 9 March 2011 laying down harmonized conditions for the marketing of construction products and repealing the Council Directive 89/106/EEC on construction products;

**EMC 2014/30/UE** Electromagnetic Compatibility Directive;

**LVD 2014/35/EU** Low Voltage Directive.

The CNBOP-PIB Certification Body in Józefów issued the Certificate of Constancy of Performance **1438-CPR-0880** for the construction product SPP-110 fire alarm sounder, confirming its compliance with the requirements of EN 54-3:2003+A1:2002+A2:2006.

The Certificate and the Declaration of Performance can be downloaded from the [www.satel.pl](http://www.satel.pl) website.

The SPP-110 fire alarm sounder has been granted the Certificate of Admittance **No 4833/2023** by the CNBOP-PIB in Józefów.

The Certificate of Admittance can be downloaded from the [www.satel.pl](http://www.satel.pl) website.



**23**

SATEL Sp. z o.o. • ul. Budowlanych 66 • 80-298 Gdańsk • POLAND

1438

1438-CPR-0880

DOP/CPR/0880

EN 54 3:2003+A1:2002+A2:2006

**Fire safety.**

**SPP-110 fire alarm sounder (type A).**

Declaration of Performance DOP/CPR/0880

Application – fire safety.

Technical specifications – please refer to this manual.